

# SMARTair™ Wall Reader

## Pro Wireless Online



**ASSA ABLOY**

**SMARTair™**  
Your Access. Your Control.

ASSA ABLOY, the global leader  
in door opening solutions

SMARTair™ wired wall readers with RFID reader are suitable for automated doors, turnstiles, barriers, elevators or any access in which the locking or blocking element is an automatism. The wall reader incorporates a relay and a control unit which manages both the reader and the relay.

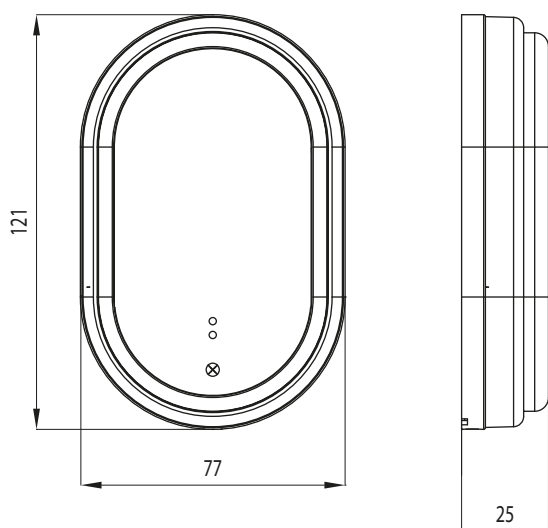

### Technical data - SMARTair™ Wall reader

	<b>Traffic volume</b>	High
	<b>Exterior usage</b>	IP55 (Wall reader) Up to 85% humidity -20°C to + 80°C (Wall reader) -10°C to + 80°C (Relay board)
	<b>Hardware compatibility and installation</b>	To be combined with electromechanical devices to unlock the door (e.g. electric strike plates, electromagnetic locks or escape routes) Cabling needed
	<b>Power supply</b>	Cabled 12-24 VAC – VDC: powered through relay board Max power consumption (reader + relay board): 500mA @ 12V / 250mA @ 24V
	<b>Multi-authentication</b>	No
	<b>Status information</b>	Door position (door sensor not included) Request to exit Tamper
	<b>Certifications</b>	CE (EMC, R&TTE) ROHS, REACH, WEE
	<b>RFID technologies</b>	HID iCLASS® MIFARE Classic and Ultralight SKIDATA DESFire
	<b>Upgradability</b>	SMARTair™ Wall readers* can be upgradeable from Standalone > Offline / Update On Card > Wireless Online by: · Adding RF module · Firmware upgrade

\* R4 circuit required.

# Electronic Technical Characteristics

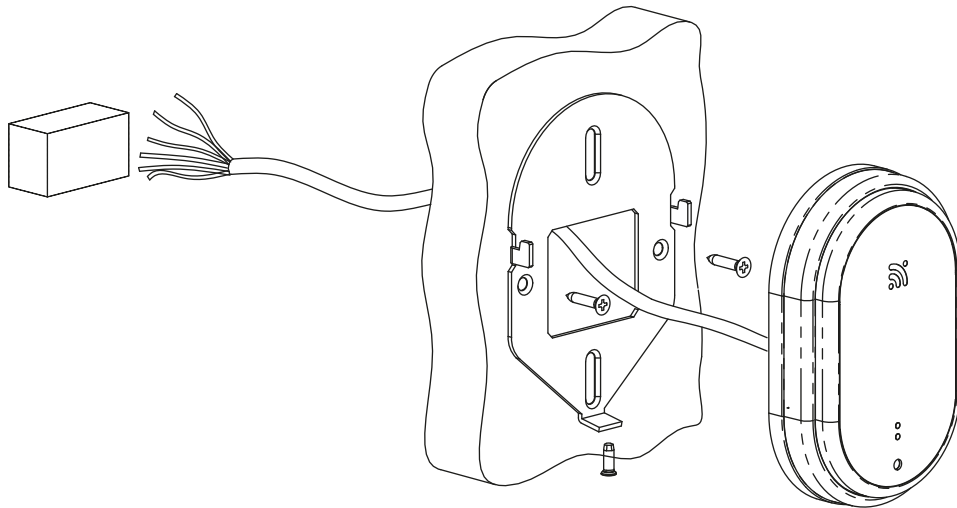

## Reader Module

- Reading distance: 2-4 cm read/write distance with standard RFID credentials.
- Emergency opening: Jack connection is available to connect the portable programmer and emergency kit.
- RFID reader with LED (green/red) and sound buzzer for different warning signals: access authorized or denied, etc.

## Control Unit

- Upgradeable firmware.
- Non-volatile memory. The wall reader can be programmed to operate in 2 modes:
  - Normal mode: 1500 users and 600 events.
  - High traffic door: unlimited number of users filtered into 48 groups (permissions). Stores 1000 events.
- Real-time clock and calendar:
  - 14 time zones with 5 time periods (week days and holidays selectable).
  - State tables: configure 20 changes of operating modes in a door per day (switch door from lock to unlock).
  - Yearly calendar: is updated every month automatically by the wireless system.
  - Automatic DST: Daylight Saving Time change. Updated with calendar.
  - Maintains clock/calendar for 48h without power supply ( internal backup battery).

## Operating modes:

- Standard: Default operating mode. Freewheeling handle until valid credential presented, then allows to open the door for 4-10 seconds (configurable).
- Standard ADA: Standard with double opening time.
- Passage mode: door is always in open mode (configured by time zones or by authorized user after double badging).
- Double user: Two valid credentials needed to open the door.
- First user: door in standard mode until first valid user enters, then will remain in passage mode (until closed by authorized user or automatically by time zone, state tables).

## RF Module

- 868MHz or 915MHz selectable in field.
- 30 configurable channels:
  - From 868,00 to 875,25 in steps of 0,25Mhz each channel.
  - From 915,00 to 922,25 in steps of 0,25Mhz each channel.
- Auto-link with communication Hubs (easy setup).
- Upgradeable firmware.

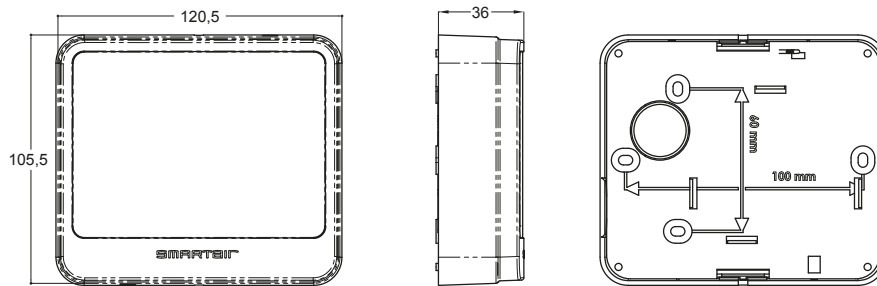

The relay board is the ideal complement for wall readers when it is necessary to manage an electrically controlled locking element from a single point, deciding for each user which elements must be activated.

Encrypted communication between reader & relay board, no manipulation on the wiring between these devices can open the door.

- Box & mounting:
  - Relay board is supplied in a box that allows surface mounting.
  - The electric board can be mounted in DIN rails (DIN rail enclosure not included). Tamper switch must be overridden or added separately.
- The two relays SMARTair™ board is a new generation product with following connections:
  - Connector for reader.
  - Power supply connector.
  - Door position (sensor not included): Intrusion or door left open will be reported.
  - Push Button: Request to exit.
  - Tamper alarm against relay board manipulation: tamper included in the board.
  - 2 output relays:
    - Relay 1 commands the electromechanical lock (not included).
    - Relay 2 can be used for other purposes. This relay functionality is configured by software or the dip switch on the board.
  - Configuration Dip switch. It can be configured from the Management Software or by this Dip.
- Other type of relay boards available for wall readers, can be acquired as spare part:
  - Simple 1 relay board with reduced size.
  - 8 output relay board: typically used in elevators. 5 of this elevator boards can be connected in serial (40 output relays).



SMARTair™ Relay Board.

ASSA ABLOY is the global leader in door opening solutions, dedicated to satisfying end-user needs for security, safety and convenience.

**ASSA ABLOY**

[www.assaabloy.com](http://www.assaabloy.com)



## **ASSA ABLOY**

TESA is the leading Spanish manufacturer and supplier of locking solutions and access control technology for the residential and institutional markets. TESA has a wide and complete range of products including panic exit devices, cylinders, security locks, knobs and handles, door closers, access control solutions with electronic cylinders, electromechanical and electromagnetic solutions and armoured doors. TESA exports to markets such as Latin America, Middle East, Europe, Asia Pacific and the North African countries.

### **SMARTair™** Your Access. Your Control.

SMARTair™ is a powerful access control system that offers an intelligent, yet simple, step up from keys. SMARTair™ is the cost-effective alternative to a full high-security system. SMARTair™ contactless, smart card technology is easily incorporated into existing systems, with multiple management solutions. No bells, whistles, or wires, just sleek, reliable security.

Talleres de Escoriaza S.A.U.  
Barrio de ventas 35  
20305 Irun  
Gipuzkoa · España  
T: +34 943 669 100  
F: +34 943 633 221  
[tesalocks@tesa.es](mailto:tesalocks@tesa.es)  
[www.tesa.es/smartair](http://www.tesa.es/smartair)